

Kuhner shaker



RIEGER

Industrievertretungen GmbH

www.rieger-iv.at

Wir sind für Sie da:

E-Mail: office@rieger-iv.at

Telefon: +43(1) 728 00 52

Fax: +43(1) 728 69 16

Rustenschacher Allee 10

1020 Wien, Austria

SB200-X (OrbShake)

Orbital shaken bioreactor
for single-use bags



SB200-X and control unit



Single-use bag with pH & DO sensors and various ports

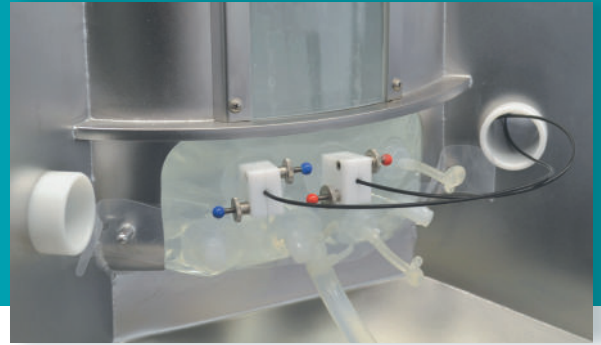

The SB200-X is an orbital shaken bioreactor for the cultivation of human, mammalian and plant cells in a single-use bag. A working volume from 50 litres up to 200 litres for the SB200-X ensures easy scale-up from microtiter plates to shaking flasks and all the way up to 200 litres. This user friendly system can be easily deployed in research, process development or production.

Performance characteristics

- + Large capacity (200L working volume) single use bioreactor system
- + Cultivation of human, mammalian and plant cells
- + Fast, simple set up
- + Easy scale-up
- + Online measurement of pH and DO

Single-use bag for a fast and simple set up

The vessel accepts a single-use bag. This bag requires no additional mixing device, enables quick set up times and eliminates elaborate cleaning and sterilising procedures. Various ports are incorporated to allow feeding, inoculation, harvesting and sampling. The bag has built in optical sensors for pH and DO **1**.

Orbital motion

The orbital motion of the SB200-X ensures efficient liquid mixing. It allows high oxygen transfer rates with low shear forces. Mechanical stress on the cells is reduced thanks to bubble-free surface gassing with almost no frothing. This motion is particularly suitable for microcarrier cultivation. The SB200-X uses the unique Kuhner direct drive which provides accurate control of the orbital speed.

2 Reader Box-X: Online measurement of pH and DO

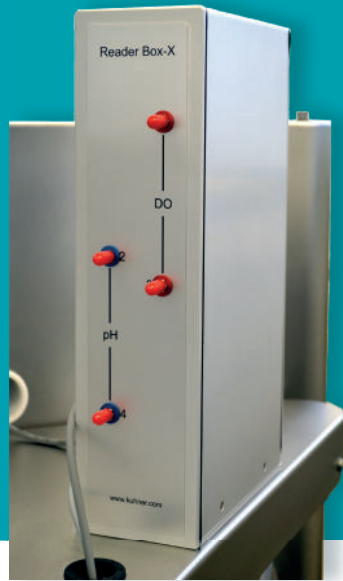

3 Filter heater

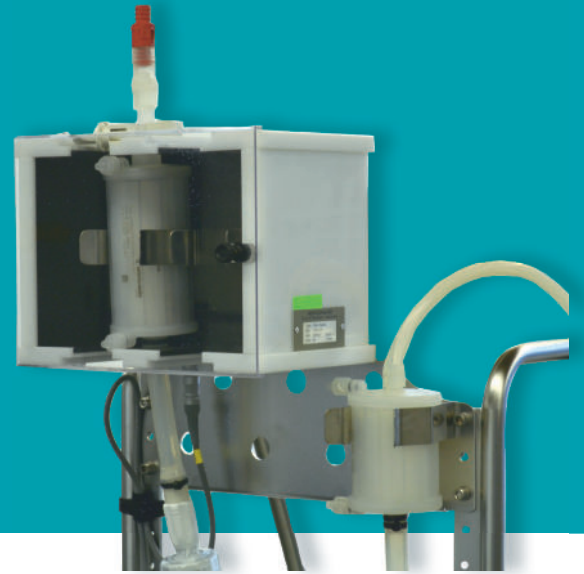

Trouble free scale-up

Another advantage of the SB200-X is easy scale-up from microtiter plates all the way up to 200 litres. The consistent hydro-dynamics of shaken bioreactors provide reproducible cultivation conditions throughout the volume range.

Control unit and online measurement

The bespoke control unit, designed by Kuhner, uses the latest touch-screen technology and Kuhner Insight software for data recording, calibration, programming and controlling. Technical controls for 21 CFR Part 11 compliance are built into the software.

The SB200-X can be heated or cooled. Temperature ramps are easily programmed and processed.

Duplex online measurement of each parameter (dissolved oxygen and pH-value in the medium) is available ensuring greater process safety 2.

Pumping system

The control unit incorporates two small and one big peristaltic pump. This enables simple regulation of the pH-value, feeding and the transfer of the culture media (scale-up or processing).

Gas mixing

The SB200-X has an integrated gas mixing device (FlowCon).

Whether stabilizing the pH with CO₂, or preventing low dissolved oxygen concentrations, the gas mixer meets all user needs. Four mass flow controllers ensure highly accurate and reproducible gas mixing. An integrated pressure sensor prevents over pressure in the bioreactor by reducing the gas flow in the first step (1. limit) and shutting off the gas flow in the second step (2. limit). Step limits can be freely programmed by the user. Integrated air filters and back pressure valves ensure interference free and long operating times for the FlowCon.

Filter heater 3

A height adjustable filter heater, with up to two exhaust filters, is installed above the vessel. Special emphasis has been placed on developing a user friendly unit. The filter heater combats any water vapour condensation in the outlet air which might cause the membranes to block. The temperature is monitored and controlled by Kuhner Insight software.

The SB200-X was developed and tested in collaboration with ExcellGene SA (Monthey, Switzerland) and the Swiss Federal Institutes of Technology EPFL (Lausanne, Switzerland).

Dimensions SB200-X

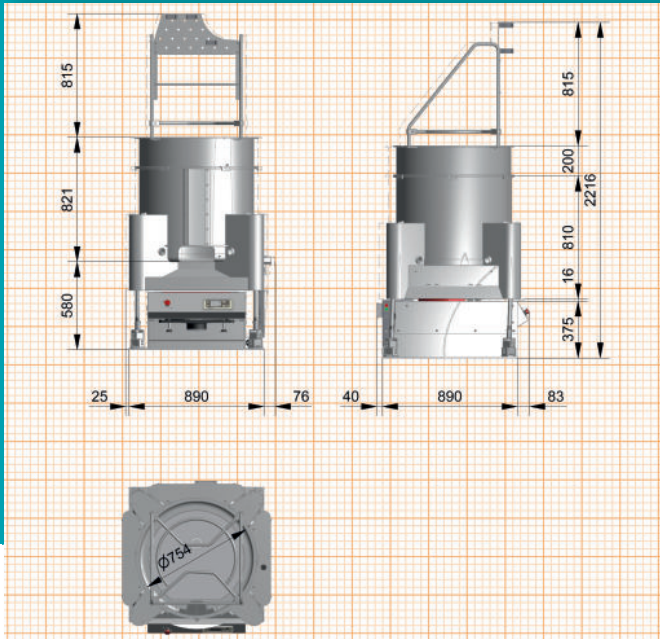

Dimensions Control unit

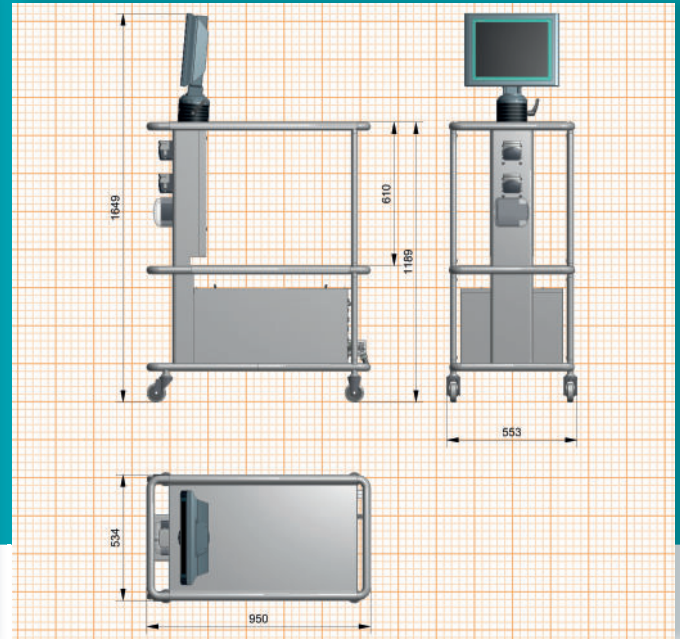

Technical data

Shaken bioreactor

Order number	SMX7100
Shaker speed	max. 80 rpm
Shaker diameter	50 mm (orbital motion)
Weight	approx. 400 kg without liquid
Accuracy, absolute	0.1 rpm
Setting, digital	1 rpm
Active brake	adjustable
Interface	CAN-Bus, RS232
Temperature	up to 40°C
Cooling	cooling coils are incorporated for connection to an external cooling system (pressure <0.2bar)
Mains connection	
SMX1021	220 - 240 V / 50-60 Hz
SMX1023	110 - 120 V / 50-60 Hz
SMX1024	95 - 105 V / 50-60 Hz

Filter heater	SMX7120
Capacity	2 exhaust filters
Temperature range	Ambient temperature up to 45°C, monitored and controlled by Kuhner Insight software
pH and DO control	Integrated in Reader Box SMX7130
pH measurement	principle: optical chemosensor
Range	pH 5.5 – pH 8.5
Accuracy (chemosensor)	± pH 0.05 at pH 7 with one point calibration ± pH 0.10 at pH 7 with pre-calibration
Drift	< pH 0.005 per day
Temperature range	up to 50°C
DO measurement	principle: optical chemosensor
Range	0% – 100% DO
Accuracy (chemosensor)	± 0.1% O ₂ at 20.9% O ₂
Accuracy (system)	± 10% DO
Drift	< 0.015% O ₂ per day
Temperature range	up to 50°C

Technical data subject to change

4 Kuhner Insight Software

5 Pumps

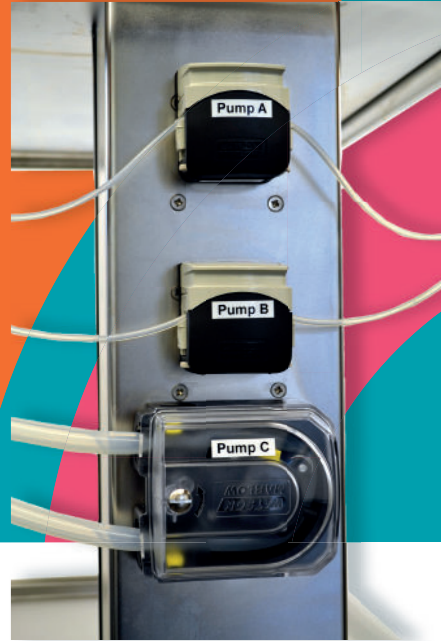

Control unit

with touchscreen monitor, software, pumps & gas mixing device

Order number	SMX7110
Weight	120kg
Monitor	15" touchscreen monitor
Software 4	Kuhner Insight for monitoring, calibration, controlling
Monitoring	O ₂ , pH, shaking speed, temperature
Calibration	pre-calibrated sensors in bag
Recalibration	one point recalibration is possible
Applicable	XP/Vista/Win7&10
GMP	21 CFR Part 11 compliant

Pumps 5			
2 small pumps (A+B)	Watson-Marlow 313VBM/D	1 big pump (C)	Watson-Marlow 520VBM/R2
Gear	10	Gear	10
Maximum Speed	100 rpm	Maximum Speed	400 rpm
Power	70 W	Power	70 W
Rollers	3	Rollers	2
Tube	1.6 mm wall tubing	Tube	2.4 mm wall tubing
Delivery Pressure	max. 2bar	Delivery Pressure	max. 2bar
1.6 mm wall tubing		2.4 mm wall tubing	
Bore diameter (mm)	Flow rates (ml/min at 100rpm)	Bore diameter (mm)	Flow rates (ml/min at 100rpm)
0.5	3.4	0.5	4.1
0.8	7	0.8	10.5
1.6	27	1.6	42
3.2	100	3.2	170
4.8	220	4.8	380
6.4	360	6.4	680
8.0	500	8.0	1040
		9.6	1500

3 Gas mixing:
Mixing up to four gases
Gas mixtures can also be connected



• **Gas mixing 6**

Number of mass flow controllers	4
Ambient conditions	5-40 [°C], max. 85 [%rH]
Input	up to 4 gases, push in connector [6 mm] (air, oxygen, nitrogen, carbon dioxide) (gas mixtures can also be connected)
Input pressure	1-2 bar
Output	1, (tube fitting for tube ID 13 [mm])
Flow rate	0 - 20 [sL/min]
Accuracy	±1.5% from the end value
Pressure sensor	integrated, 0-400 [mbar], programmable prevents over pressure in the connected vessel
Air filter	integrated, prevents blocking the mass flow controllers
Back pressure valve	integrated, prevents reflux into the mass flow controllers
Controlled filter heating box	for the outlet filters, prevents blocking of the filters caused by condensation (only air inlet and outlet with silicon tubing)
C-Flex material	for the tubing, enables the user to connect additional components via tube welding

Technical data subject to change



Options

Cooling

The SB200-X has a cooling ring embedded in the base plate. Cooling is achieved by connecting an external cooling device. An integrated valve, controlled by the software, regulates the set point temperature.

IQ-OQ Documentation

IQ-OQ (Installation Qualification and Operation Qualification) is an equipment qualification required for GMP procedures. Documentation is available from Kuhner and Qualification services can also be provided at the customer's premises.

Tubing support bar

Order number: SMX714001

A tubing support bar is available for attaching the various tubes (feeding, medium, air and pH regulation) and keeping them tidy.

Accessories

Single-use bag

Order number: SMX710001

The gamma irradiated bag for the Kuhner shaken bioreactor requires no additional mixing device, enables quick set up times and eliminates elaborate cleaning and sterilising procedures. The single-use bag has a working volume from 50 litres up to 200 litres. Various ports are incorporated to allow feeding, inoculation, harvesting and sampling. The bag has built in optical sensors for pH and DO.

Interfaces

Kuhner shakers are equipped with a CAN-bus. CAN-USB, CAN-Ethernet, EMI-60 and NET-60 are all well established interfaces.



Shakers & Accessories

www.kuhner.com

Kuhner

Represented by:

Adolf Kühner AG • since 1949

Dinkelbergstrasse 1
CH-4127 Birsfelden (Basel)
Switzerland

phone +41 (0) 61 319 93 93
fax +41 (0) 61 319 93 94
office@kuhner.com

www.kuhner.com